

FLUSH MOUNT PLATE - FRONT VIEW

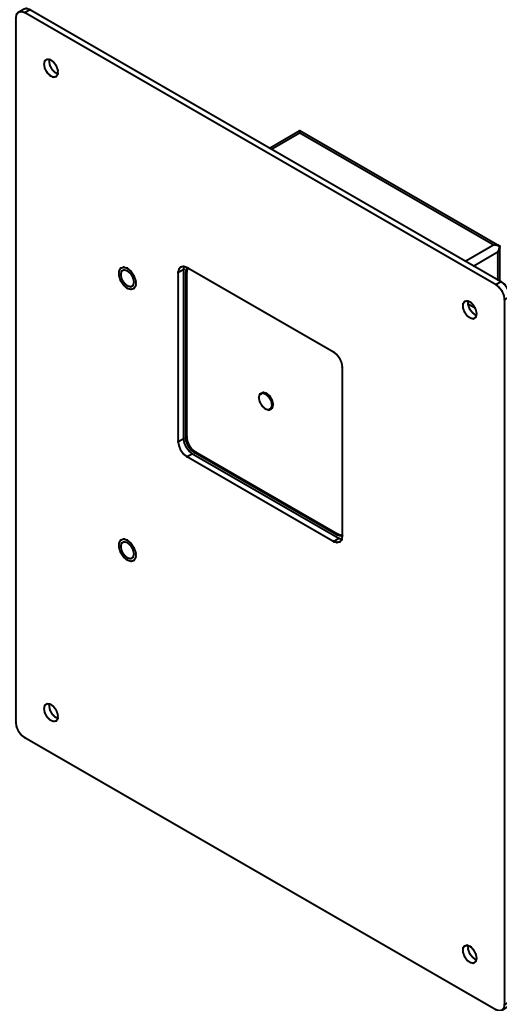

FRONT ISO VIEW

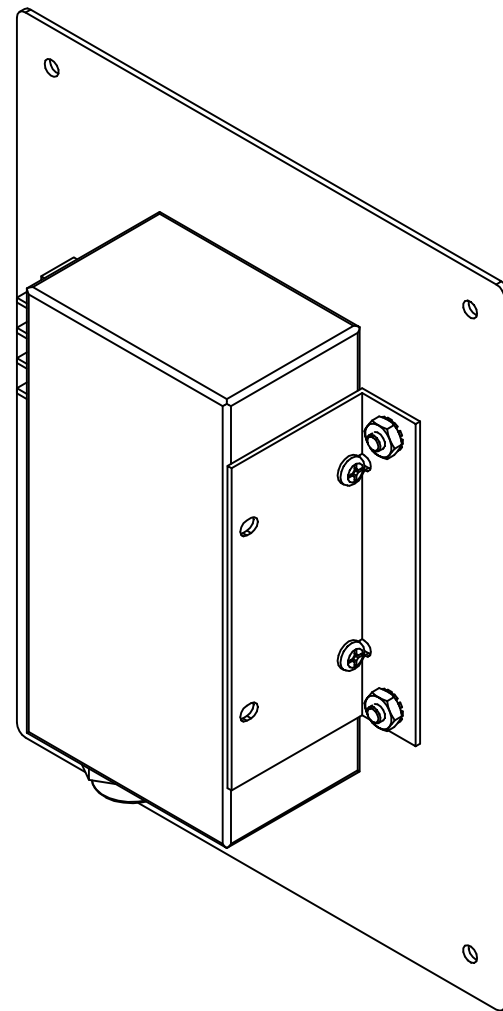

REAR ISO VIEW

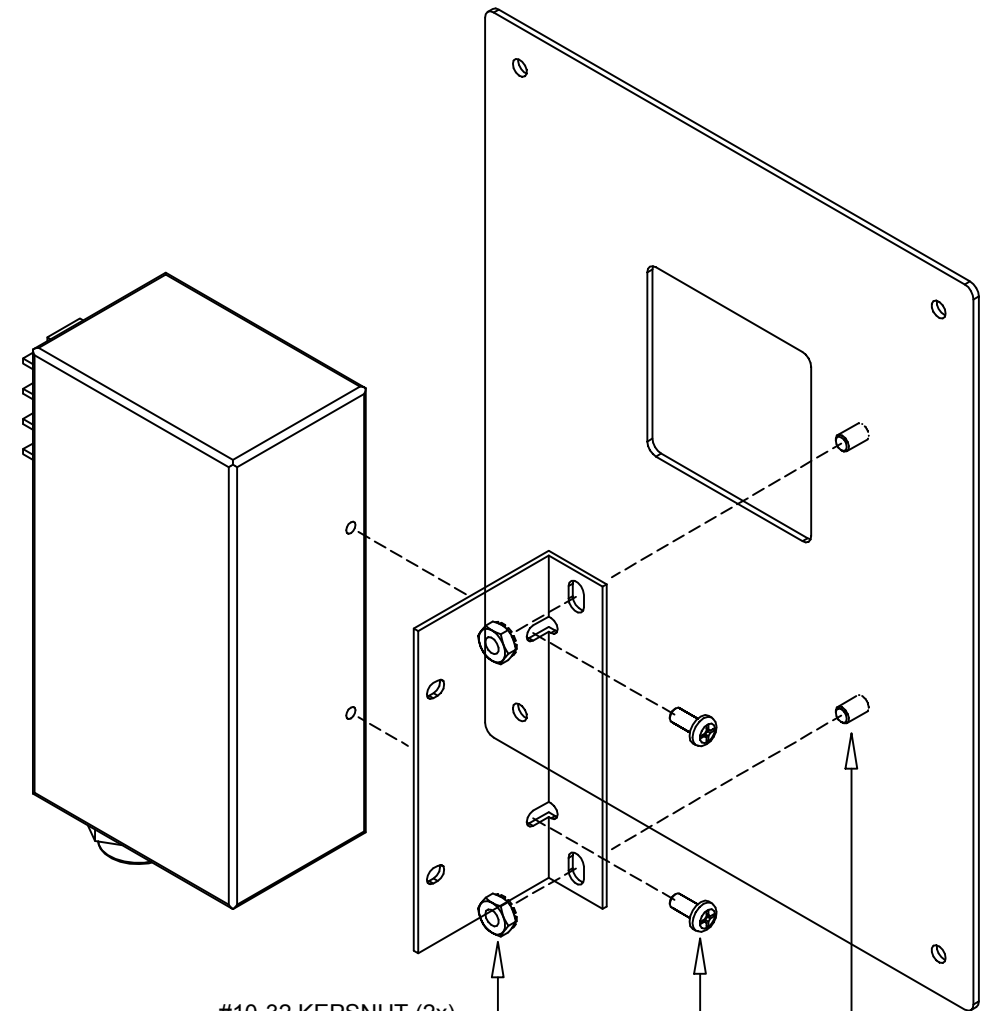

#10-32 KEPSNUT (2x)

#8 THREAD FORMING SCREW (2x)

#10-32 PRESS-FIT STUD (2x)

EXPLODED REAR ISO VIEW

MATERIAL: — FINISH: —

UNLESS OTHERWISE SPECIFIED: ALL DIMENSIONS IN INCHES
 INSIDE BEND RADIUS .030 MAX
 REMOVE ALL BURRS AND SHARP EDGES

TOLERANCE: x.xx = ±.030 HOLE Ø = ±.005
 x.xxx = ±.015 ANGLE = ±1/2°

1	PRELIMINARY	BJW	-	06/28/04
ISSUE	DESCRIPTION	BY	APPVD	DATE

Danaher Power Solutions
 5900 EASTPORT BLVD - RICHMOND, VA 23231-4453

THIS DOCUMENT IS THE PROPERTY OF DANAHER POWER SOLUTIONS. UNDER COPYRIGHT LAW, NO PART OF THIS DOCUMENT, REPRODUCTIONS OF IT, OR INFORMATION DERIVED FROM IT IS TO BE GIVEN TO OTHERS WITHOUT WRITTEN AUTHORIZATION FROM DANAHER-DPS

STATUS	SCALE	DRWN: BJW	CHKD: -
-	1:2	APPVD: -	DATE: -
TITLE			DWG. SIZE, NUMBER
PK Series Mounting Options			Bxxxxx-1
SHEET 1			OF 2